



Serve every customer with heart!



ZHIGOU TECHNOLOGY INTELLIGENT RETAIL TERMINAL PRODUCT INTRODUCTION

Integrated Research And Development,
Manufacturing, Sales, And Supply Chain

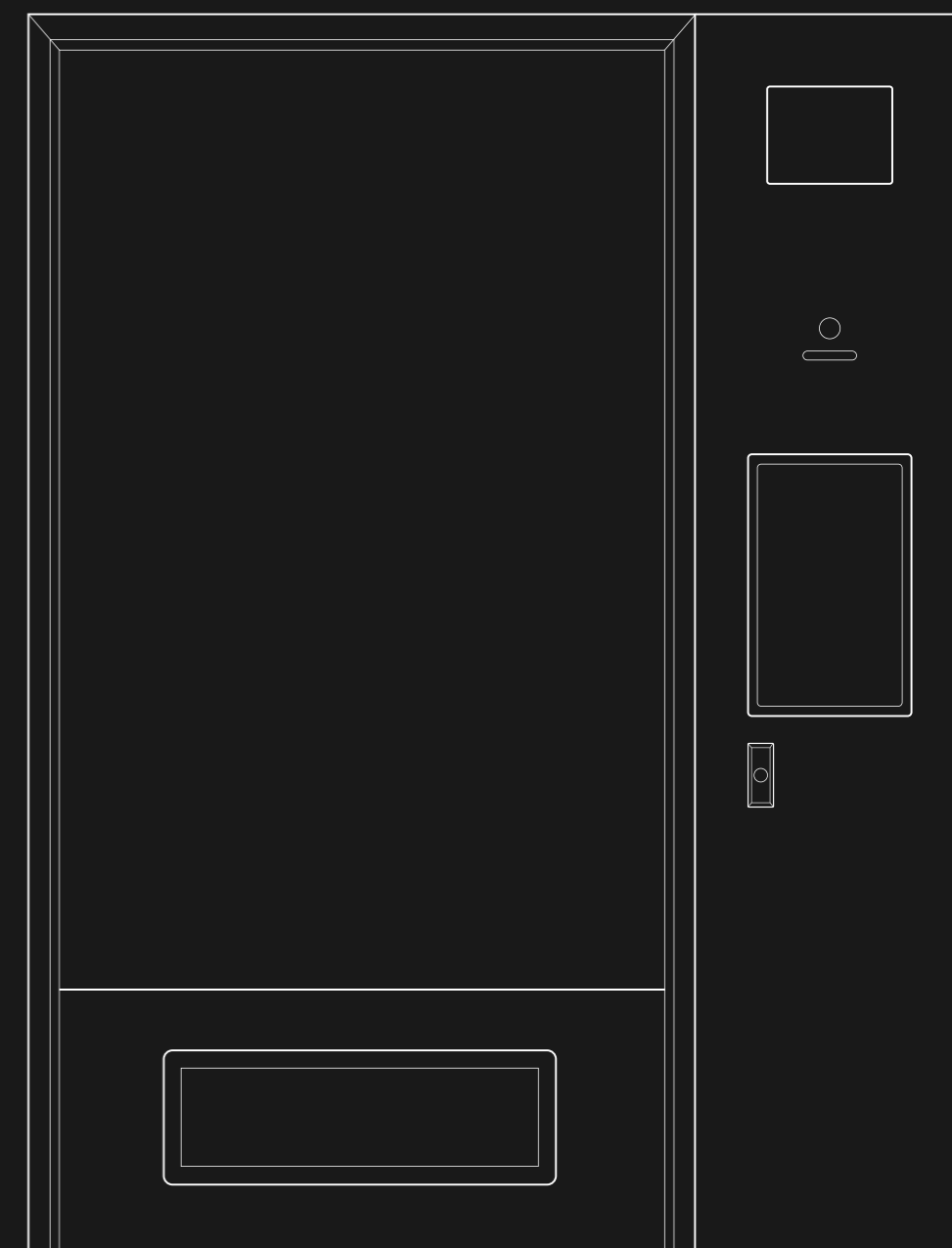

XI' AN ZHIGOU INTELLIGENT TECHNOLOGY CO., LTD

Add:Room 1233, Block A, Eurasia International, Xi 'an, Shaanxi

Web: www.zhigoukeji.com

Email: henanzhigou@163.com TEL: 400-668-0921

Brand spokesperson
Speed skating champion

韩天宇



CONTENTS

1 GLITTER SILVER PRODUCT

ZG-ZL-N36(S8)	15-16
ZG-ZL-N60	17-18
ZG-ZL-N60(S8)	19-20
ZG-ZL-N120(S8)	21-22
ZG-ZL-N60(S15.6)	23-24
ZG-ZL-N120(S15.6)	25-26
ZG-ZL-N60(S21.5)	27-28
ZG-ZL-N120(S21.5)	29-30
ZG-ZL-N36-(S4)-AJ	31-32
ZG-ZL-N60-(S4)-AJ	33-34

3

OTHER PRODUCTS

15.6 inch 30 cargo lanes +14 grids	41
15.6 inch 30 goods channel +14 +16	42
21.5-inch touch screen room temperature grain and oil cabinet	43
21.5-inch touchscreen labor protection machine	44
Commemorative coin vending machine	45
Automatic visa machine	46

ABOUT US

ENTERPRISE CULTURE

Company profile	01
Qualification certification	02
Business partner	03
After-sales service	04
Application scenario	05
Customized service	06
Freight channel design	07-09
Payment System	10-11
Backend system	12

2

GRID CABINET

15.6 INCH 60 CARGO CHANNEL +18 GRIDS	37-38
18 GRIDS/ 27GRIDS	39
40 GRIDS/ 60GRIDS	40

4

CUSTOMER CASE

.....



CERTIFICATION OF QUALIFICATION



COMPANY PROFILE

ZHIGOU technology brand was founded in 2017, set vending machine R&D/production/sales in one of the enterprises, to provide intelligent automatic sales solutions for various fields, products are widely used in schools, high-speed rail, airports, stations, shopping malls, hospitals and enterprises and other places. The categories of self-service sales cover food, beverages, stationery, books, toys, clothing, medicines and family planning supplies, lunch boxes, fresh juice and other fields, and the realization of cash, scanning code, face brush, credit card and other payment methods and GPRS remote management control system.

Xi 'an ZHIGOU Intelligent Technology Co., Ltd. as a global leader in the vending machine industry, always adhere to technology and quality peer, dare to innovate. Smart purchase technology has always been focused on good quality, drafting T/HEBQIA194-2023 vending machine group standards, and obtained ISO9001 quality system certification, Europe and the united states CE certification, customer-centric, with excellent service system for brand extension, after-sales service outlets branch more than 600 cities at home and abroad, Strive to create a more attractive vending machine brand and a more valuable vending machine brand in the world.

80000m²
Factory floor space

2000+
Number of employees of Smart purchase

30+
Hardware development team

20+
Software development team



Workshop - Fully automatic motor assembly



Workshop - vending machine tray



COOPERATIVE PARTNER



1 YEAR MACHINE WARRANTY 15000+ service outlets nationwide



Pay attention to [wisdom purchase technology] public number

8 MAJOR SERVICE GUARANTEES

Free delivery	Local after-sales	Complete machine warranty	Many-to-one service
Home delivery	National guarantee	Free background upgrade	One year warranty

WORRY FREE AFTER SALE

15 days no reason to return or exchange <small>15 days no reason to return or exchange</small>	Genuine guarantee <small>Official genuine</small>	Regular invoice <small>Regular machine printing invoice</small>	The whole machine warranty is 1 year <small>National warranty after-sales worry free</small>

400+ Enterprises in various industries | 100+ Listed company | 50+ Strategic partner | 1亿+ Cumulative coverage user



| Mall

| Hospital

| Exhibition

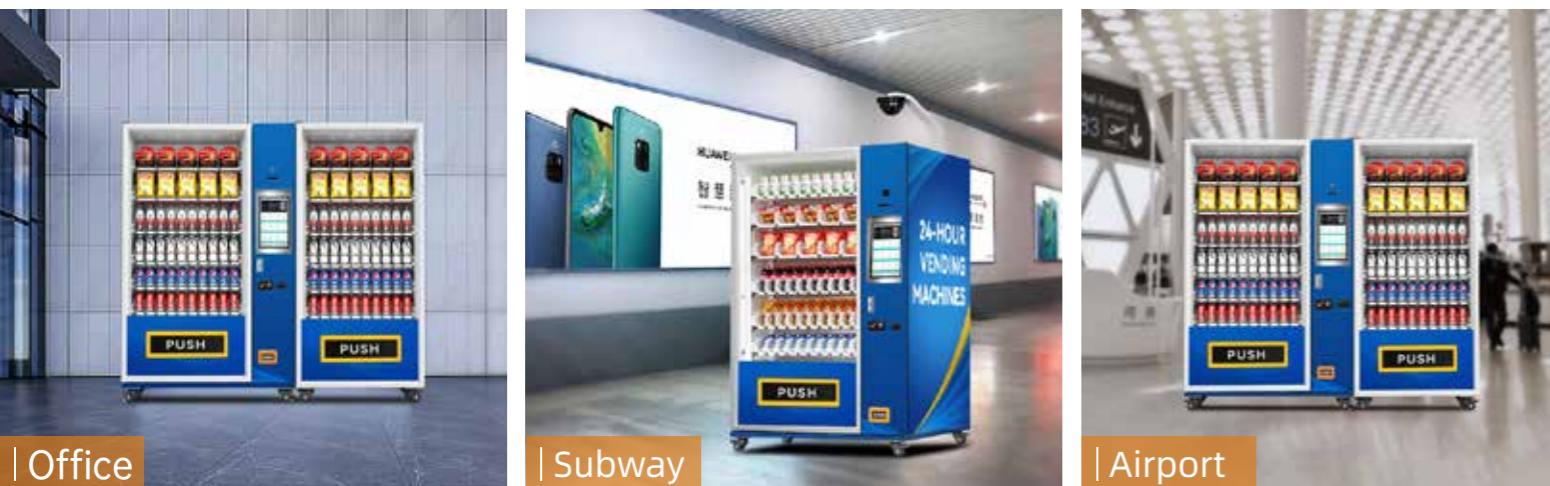

| Office

| Subway

| Airport

OEM/ODM CUSTOMIZATION SERVICE OEM/ODM



Both parties negotiated and confirmed the machine customization plan



Hardware and software engineers develop products according to the customer's functional requirements



Structural engineers and appearance engineers design structure and appearance



Client to confirm



Make molds and produce samples



The first batch of prototypes were delivered to customers for testing



According to the confirmed prototype for labeling, mass production for clients

APPLICATION SCENARIO

- No installation, flexible device placement
- Scientific management, remote positioning and accurate distribution
- 24 hours 400 customer service hotline, anytime to solve your problems
- 15,000 vending machines, remote data management, real-time monitoring of sales and fault information
- First-line brand beverages, hot selling goods are constantly updated, and fresh and direct delivery by manufacturers to ensure food safety

STANDARD SPIRAL DIMENSIONS AND CAPACITY REFERENCES

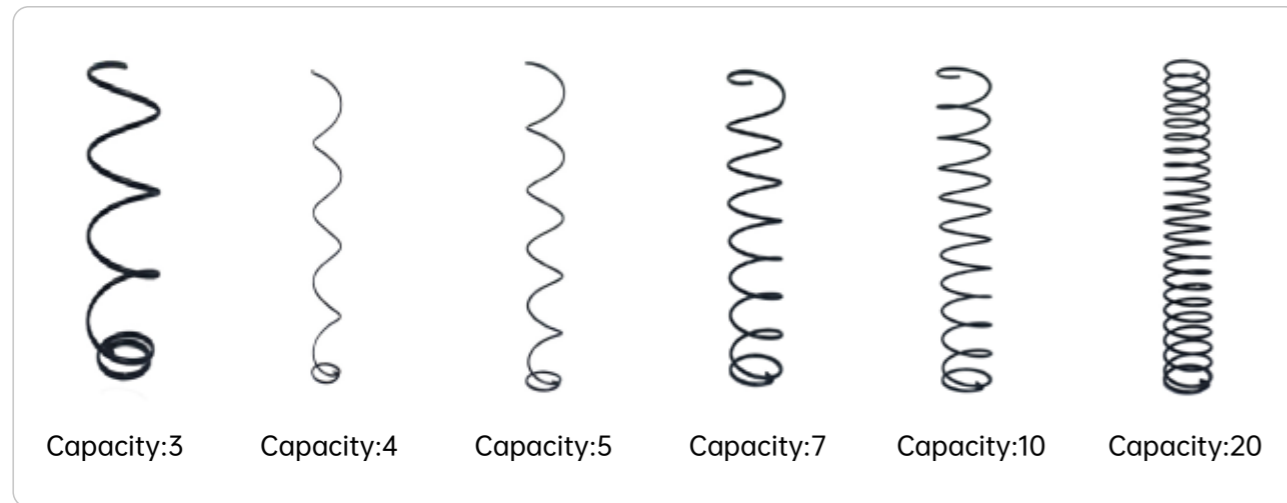

Spring locking position	Spring diameter (mm)	Available space spacing (mm)	Spring steel wire diameter (mm)	Spring Total length (mm)	Notes
3 cards	87	115	4	440	Large adult products
4 cards	87	92	4	440	Cup noodles
5 cards	67	72	4	440	Drinks
7 cards	67	52	4	440	adult erotica products
10 cards	67	32	4	440	smoke
20 cards	67	16	4	440	We need samples
25 cards	67	13	4	440	We need samples
Double 3 cards	87	103-113	4	440	We need samples
Double 4 cards	87	70-92	4	440	We need samples
Double 5 cards	67	68-72	4	440	We need samples
Double 7 cards	67	48-52	4	440	We need samples
Double 10 cards	67	28-32	4	440	We need samples
Double 20 cards	67	12-16	4	440	We need samples
Double 25 cards	67	13	4	440	Medical record book

PRODUCT CONFIGURATION

The goods channel can be customized to sell a wider variety of products

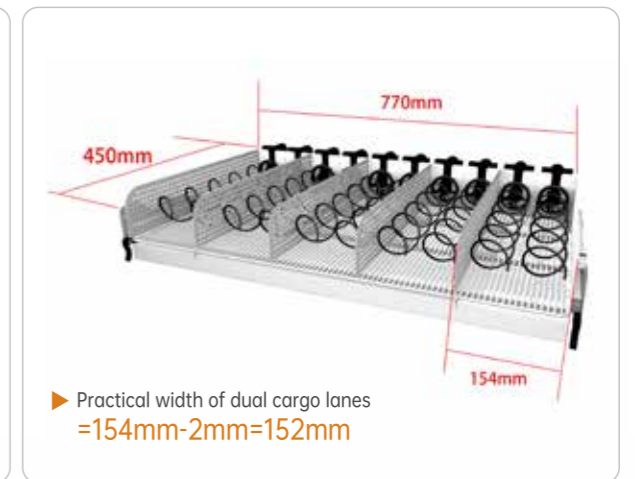
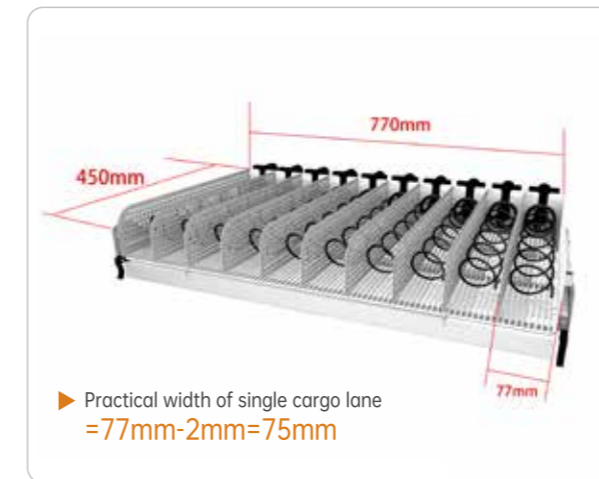

bottled drinks		Cargo channel capacity: x5 x5 x5 x5 x5 x5 x5 x5 x5 x5
Bucket instant noodles		Cargo channel capacity: x3 x3 x3 x3 x3
snake		Cargo channel capacity: x5 x5 x5 x5 x5
bottled drinks		Cargo channel capacity: x5 x5 x5 x5 x5 x5 x5 x5 x5 x5
bottled drinks		Cargo channel capacity: x5 x5 x5 x5 x5 x5 x5 x5 x5 x5
canned drink		Cargo channel capacity: x5 x5 x5 x5 x5 x5 x5 x5 x5 x5



Standard tray (mm):	10 goods pallets	9 goods pallets	8 goods pallets	5 goods pallets	4 goods pallets	3 goods pallets
Single goods channel width(mm):	76	84	95	152	191	255

SINGLE CARGO CHANNE DESIGN

A-type goods channel information



B-type goods channel information



C-type goods channel information

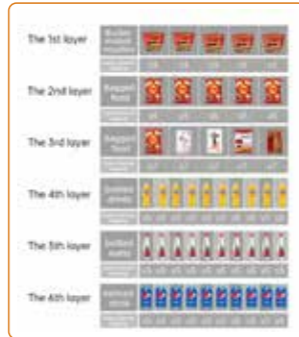

D-type goods channel information



E-type goods channel information



F-type goods channel information



DESIGN OF COMBINED CONTAINER CHANNEL SALES

A-type goods channel information

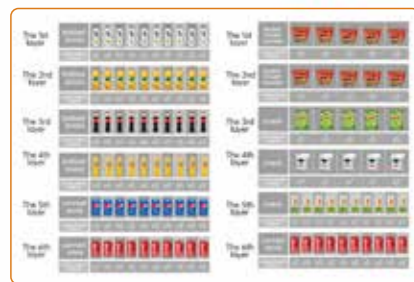

B-type goods channel information

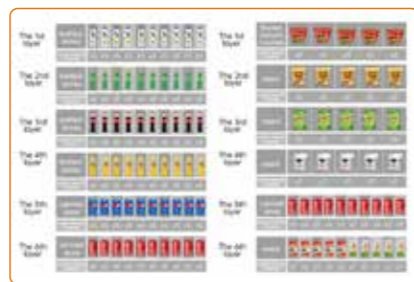

C-type goods channel information

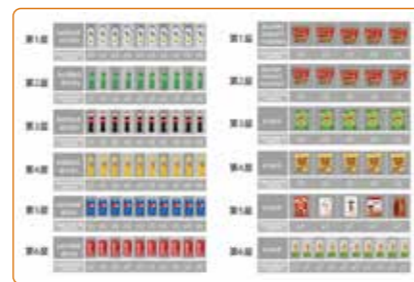

D-type goods channel information

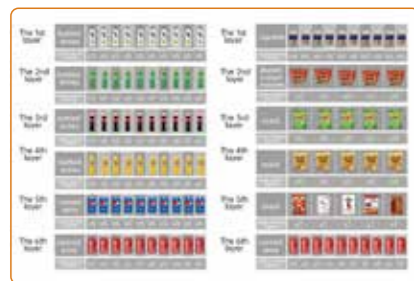

E-type goods channel information

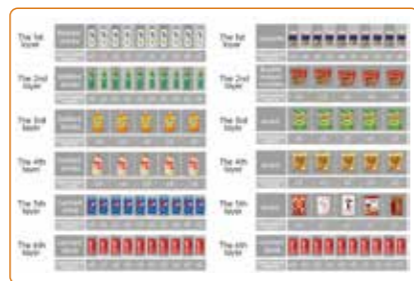

PAYMENT SYSTEM

More convenient ways to pay More options can be choose for actual requirement



Credit Card Payment



Cash/Coin Payment



NFC/Apple
Android
Payment



OR Code
Payment



Wechat Pay



Alipay



Face
Recognition

WE SUPPORT AS BELOW

Bill acceptor



Cashless



Coin changer



PAYMENT SYSTEM

NayaxCard readers can use multiple payment methods, including but not limited to Visa, Mastercard, American Express, JCB, Discover, UnionPay-Twint, Resto Flash, SafeCharge, Castles Technology, Apple Pay, Google Pay, Samsung Pay, Alipay, WeChat Pay, Paytm, M-Pesa, Sodexo, Global Payments, Telit, Interac, MobilePay, Swish, Vipps, SumUp, izly, Pyramid Technologies Inc., Verizon, Elavon, First Data, BBVA Alipay, AT&T, etc. These payment methods cover various types such as credit/debit cards, mobile payments, electronic wallets, etc.

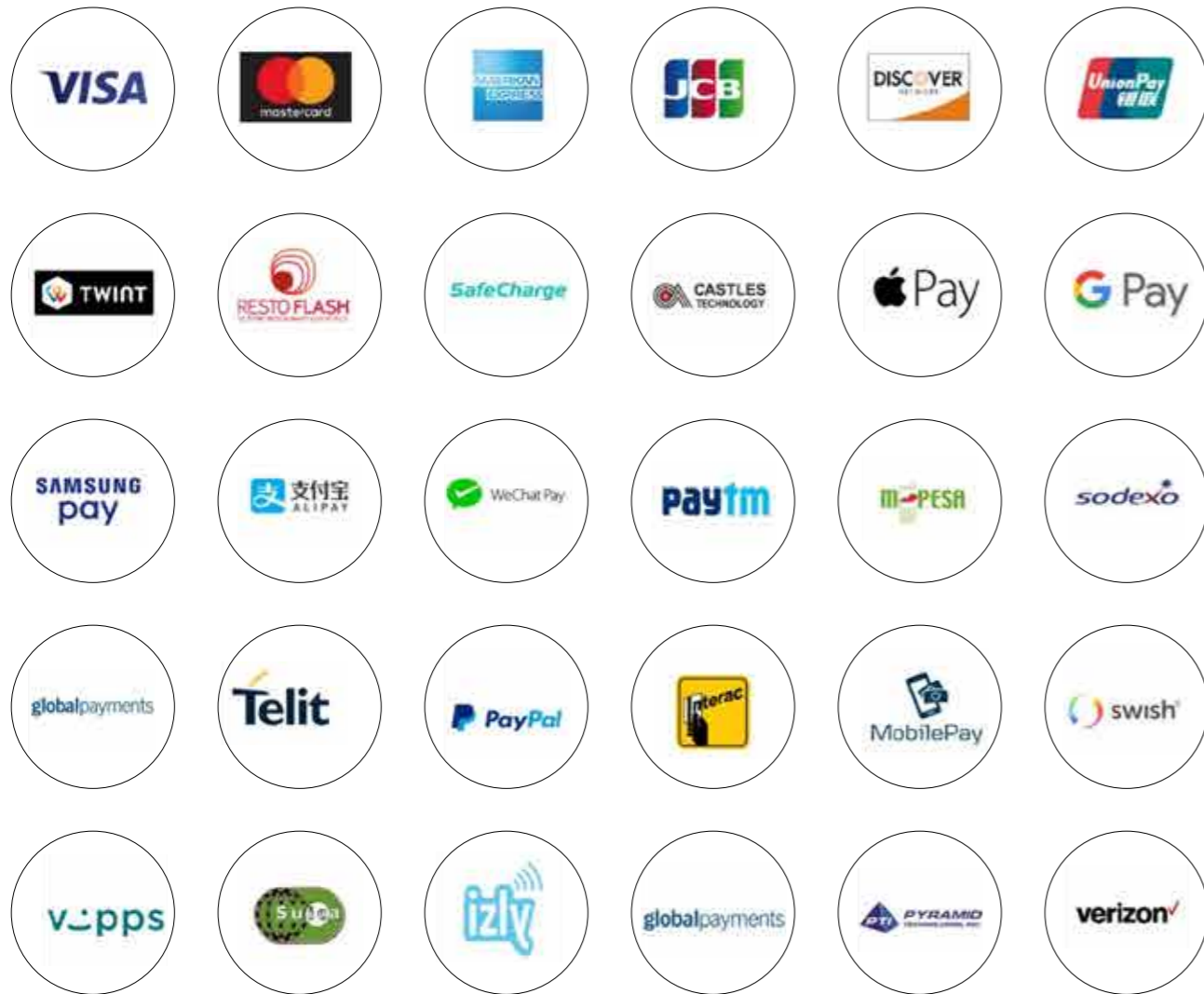

BACKGROUND MANAGEMENT SYSTEM

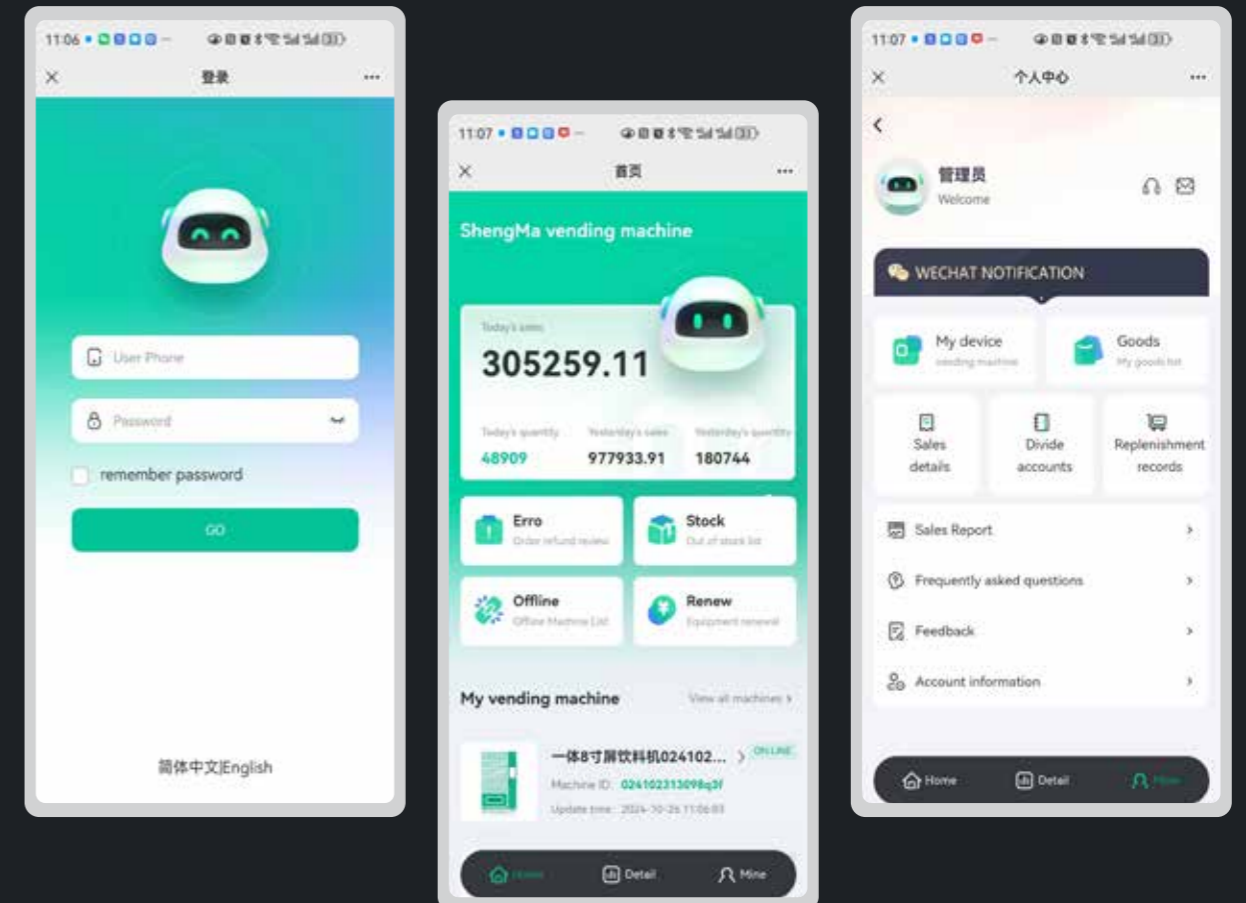
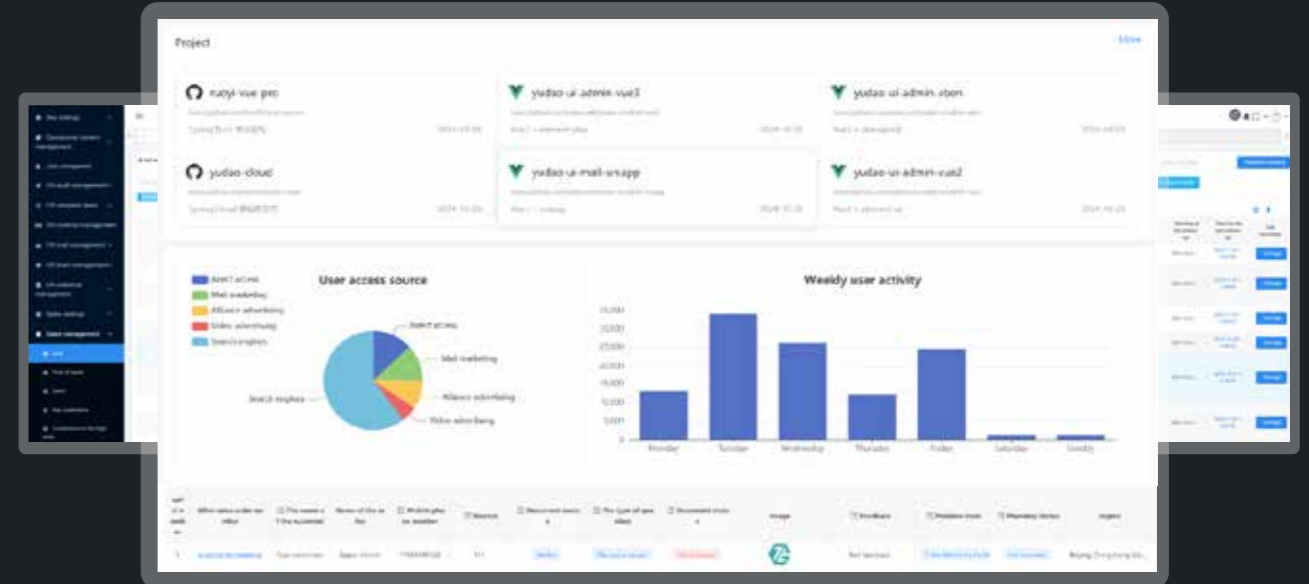

Spring machine series





PRODUCT PARAMETER

8 INCH -36 GOODS CHANNEL

GOOD QUALITY INTELLIGENT PURCHASE

AI smart face vending machine



Mobile remote control
Remote audit/price change/
lighting/temperature



Intelligent temperature control
Cold and hot dual temperature
intelligent regulation



Instant receipt
Customer funds arrive more assured



Ultra-large capacity
Can carry 300-800 items



Put an end to arbitrary charges
Smart background is free to use



Adjustable cargo channel
Height and width can be adjusted

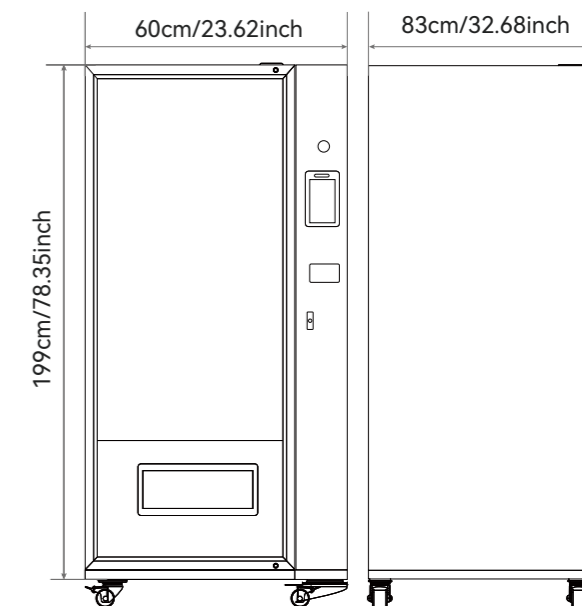

PRODUCT PARAMETERS: 36channels 60 kinds of goods 360capacity

Device model: ZG-ZL-N36-S8

Device size: 600x830x1990mm

Pre-packed size: 650x880x2000mm

Rated voltage: 220V/50HZ

Ambient temperature: cooling temperature

Room temperature power: 35W

Cooling power: 460W

Heating power: 500W (optional)

Defogging power: 40W (optional)

Inventory: 180~360 pieces

Refrigerant number: R290

Weight: 122kg

Pre-packed weight: 124kg

PRODUCT PARAMETER

60 GOODS CHANNEL

GOOD QUALITY INTELLIGENT PURCHASE

AI smart face vending machine



Mobile remote control
Remote audit/price change/
lighting/temperature



Intelligent temperature control
Cold and hot dual temperature
intelligent regulation



Instant receipt
Customer funds arrive more assured



Ultra-large capacity
Can carry 300-800 items



Put an end to arbitrary charges
Smart background is free to use



Adjustable cargo channel
Height and width can be adjusted

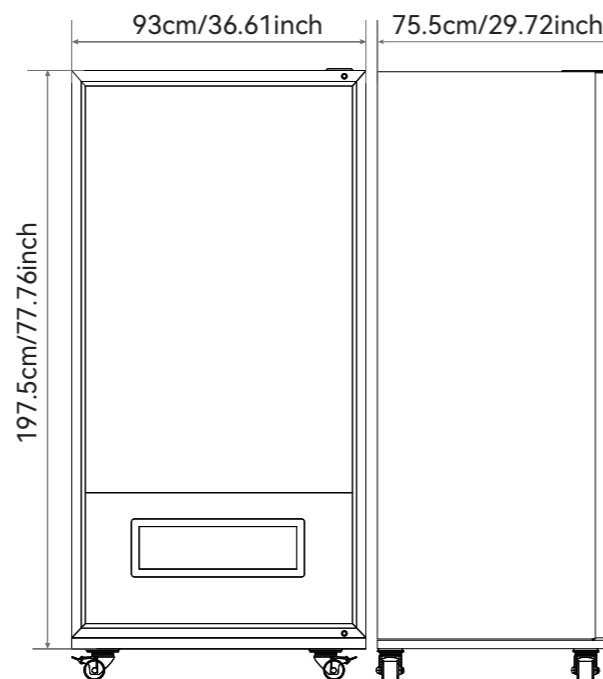

PRODUCT PARAMETERS: 60 channels 60 kinds of goods 600 capacity

Device model: ZG-ZL-N60

Equipment size: 930x755x1975mm

Pre-packed size: 980x800x1990mm

Rated voltage: 220V/50HZ

Ambient temperature: normal temperature

Room temperature power: 25W

Inventory: 300~600 pieces

Refrigerant number: R290

Weight: 145kg

Pre-packed weight: 1148kg





PRODUCT PARAMETER

8 INCH -60 GOODS CHANNEL

GOOD QUALITY INTELLIGENT PURCHASE

AI smart face vending machine



Mobile remote control
Remote audit/price change/
lighting/temperature



Intelligent temperature control
Cold and hot dual temperature
intelligent regulation



Instant receipt
Customer funds arrive more assured



Ultra-large capacity
Can carry 300-800 items



Put an end to arbitrary charges
Smart background is free to use



Adjustable cargo channel
Height and width can be adjusted

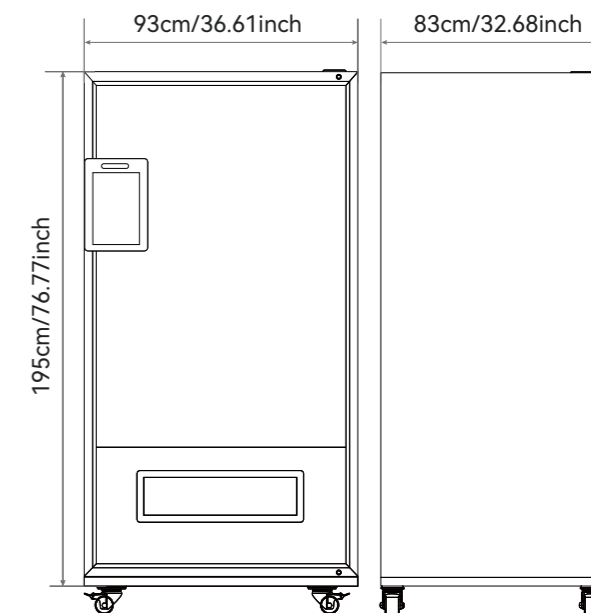

PRODUCT PARAMETERS: 60 channels 60 kinds of goods 600 capacity

Device model: ZG-ZL-N60-S8

Device size: 930x830x1950mm

Pre-packed size: 980x890x1950mm

Rated voltage: 220V/50HZ

Ambient temperature: cooling temperature

Room temperature power: 35W

Cooling power: 460W

Heating power: 500W (optional)

Defogging power: 40W (optional)

Inventory: 300~600 pieces

Refrigerant number: R290

Weight: 168kg







Pre-packed weight: 171kg

PRODUCT PARAMETER

8 INCH -120 GOODS CHANNEL

GOOD QUALITY INTELLIGENT PURCHASE

AI smart face vending machine

-  **Mobile remote control**
Remote audit/price change/lighting/temperature
-  **Intelligent temperature control**
Cold and hot dual temperature intelligent regulation
-  **Instant receipt**
Customer funds arrive more assured
-  **Ultra-large capacity**
Can carry 300-800 items
-  **Put an end to arbitrary charges**
Smart background is free to use
-  **Adjustable cargo channel**
Height and width can be adjusted

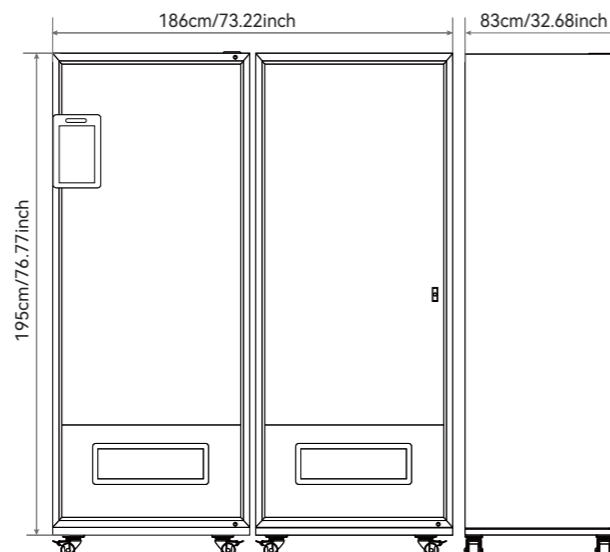

PRODUCT PARAMETERS: 120 channels 120 kinds of goods 1200 capacity

Device model: ZG-ZL-N60-S8+ZG-CW-N60

Equipment size: (main cabinet: 930x830x1950mm sub-cabinet :930*755*1975mm)

Pre-packed size: (main cabinet :980x890x1950mm sub-cabinet :980*800*1990mm)

Rated voltage: 220V/50HZ

Ambient temperature: cooling temperature + room temperature

Room temperature power: 35W+25W

Cooling power: 460W

Heating power: 500W (optional)

Defogging power: 40W (optional)

Inventory: 600~1200 pieces

Refrigerant number: R290

Weight: 313kg

Pre-packed weight: 319kg











PRODUCT PARAMETER

15.6 INCH -60 GOODS CHANNEL

GOOD QUALITY INTELLIGENT PURCHASE

AI smart face vending machine

 <p>Mobile remote control Remote audit/price change/ lighting/temperature</p>	 <p>Intelligent temperature control Cold and hot dual temperature intelligent regulation</p>	 <p>Instant receipt Customer funds arrive more assured</p>
 <p>Ultra-large capacity Can carry 300-800 items</p>	 <p>Put an end to arbitrary charges Smart background is free to use</p>	 <p>Adjustable cargo channel Height and width can be adjusted</p>

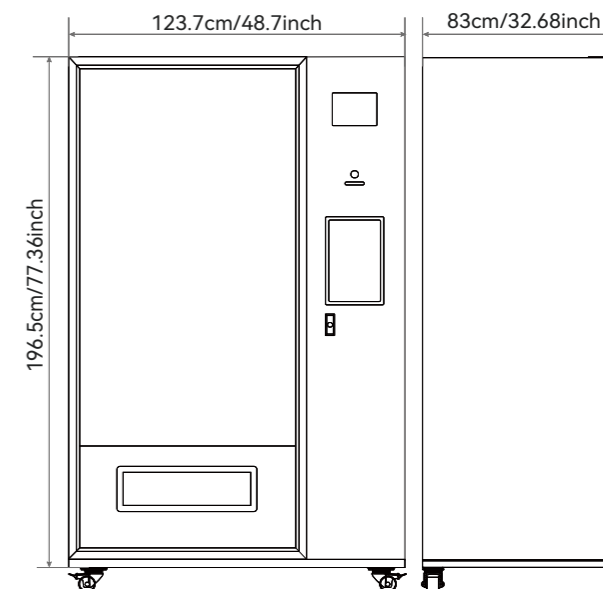

PRODUCT PARAMETERS: 60 channels 60 kinds of goods 600 capacity

Device model: ZG-ZL-N60-S15.6

Device size: 1237x830x1965mm

Pre-packed size: 1280x880x1980mm

Rated voltage: 220V/50HZ

Ambient temperature: cooling temperature

Room temperature power: 40W

Cooling power: 460W

Heating power: 500W (optional)

Defogging power: 40W (optional)

Inventory: 300~600 pieces

Refrigerant number: R290

Weight: 208kg

Pre-packed weight: 212kg

PRODUCT PARAMETER

15.6 INCH -120 GOODS CHANNEL

GOOD QUALITY INTELLIGENT PURCHASE

AI smart face vending machine

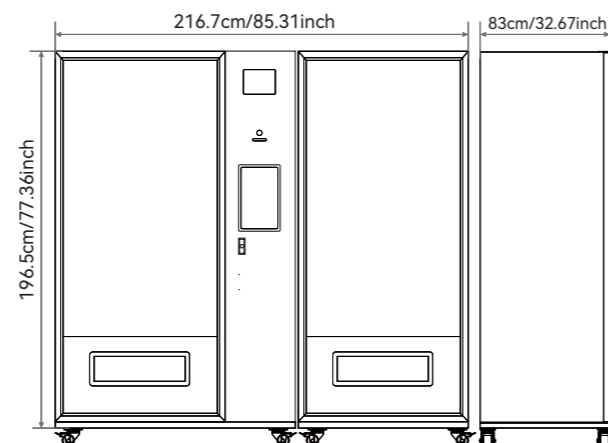
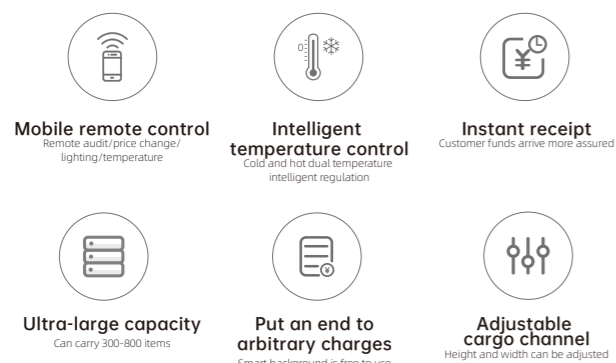

PRODUCT PARAMETERS: 120 channels 120 kinds of goods 1200 capacity

Device model: ZG-ZL-N60-S15.6+ZG-CW-N60

Equipment size: (main cabinet: 1237x830x1965mm Auxiliary cabinet :930*755*1975mm)

Pre-packing size: (main cabinet :1280x880x1980mm sub-cabinet :980*800*1990mm)

Rated voltage: 220V/50HZ Ambient temperature: cooling temperature + room temperature

Room temperature power: 40W+25W

Cooling power: 460W

Heating power: 500W (optional)

Defogging power: 40W (optional)

Inventory: 600~1200 pieces

Refrigerant number: R290

Weight: 353kg







Pre-packed weight: 360kg



PRODUCT PARAMETER

21.5 INCH -60 GOODS CHANNEL GOOD QUALITY INTELLIGENT PURCHASE

AI smart face vending machine

-  **Mobile remote control**
Remote audio price change/
lighting/temperature
-  **Intelligent temperature control**
Cold and hot dual temperature
intelligent regulation
-  **Instant receipt**
Customer funds arrive more assured
-  **Ultra-large capacity**
Can carry 300-800 items
-  **Put an end to arbitrary charges**
Smart background is free to use
-  **Adjustable cargo channel**
Height and width can be adjusted

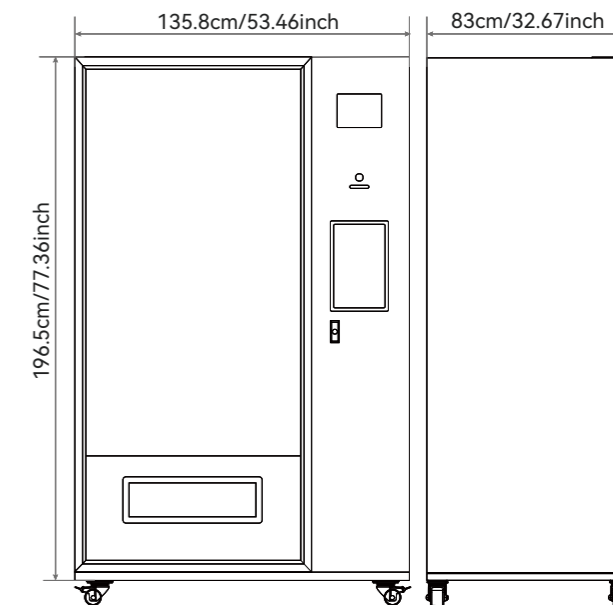

PRODUCT PARAMETERS: 60 channels 60 kinds of goods 600 capacity

Device model: ZG-ZL-N60-S21.5

Device size: 1358x830x1965mm

Pre-packed size: 1410x860x1965mm

Rated voltage: 220V/50HZ

Ambient temperature: cooling temperature

Room temperature power: 40W

Cooling power: 500W

Heating power: 500W (optional)

Defogging power: 40W (optional)

Inventory: 300~600 pieces

Refrigerant number: R290

Weight: 218kg

Pre-packed weight: 222kg

PRODUCT PARAMETER

21.5 INCH -120 GOODS CHANNEL GOOD QUALITY INTELLIGENT PURCHASE

AI smart face vending machine

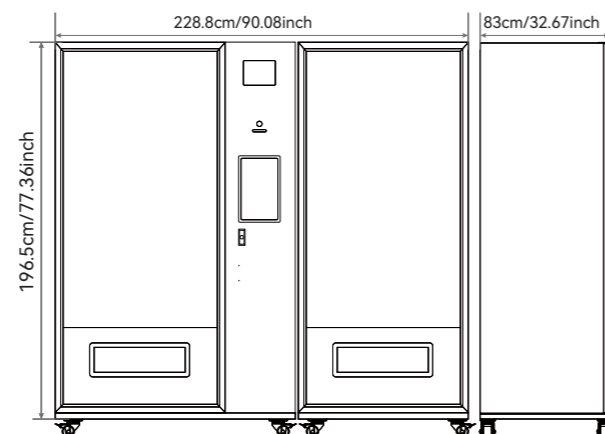
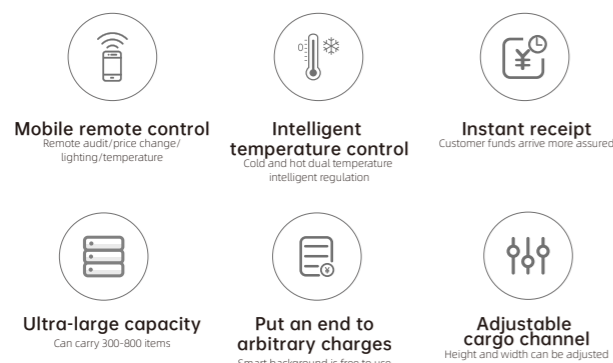

PRODUCT PARAMETERS: 120 channels 120 kinds of goods 1200 capacity

Device model: ZG-ZL-N60-S21.5+ZG-CW-N60

Equipment size: (main cabinet: 1358x830x1965mm Auxiliary cabinet :930*755*1975mm)

Pre-packed size: (main cabinet :1410x860x1980mm sub-cabinet :980*800*1990mm)

Rated voltage: 220V/50HZ

Ambient temperature: cooling temperature + room temperature

Room temperature power: 40W+25W

Cooling power: 500W

Heating power: 500W (optional)

Defogging power: 40W (optional)

Inventory: 600~1200 pieces

Refrigerant number: R290

Weight: 363kg

Pre-packed weight: 370kg





PRODUCT PARAMETER

5 INCH -36 GOODS CHANNEL

GOOD QUALITY INTELLIGENT PURCHASE

AI smart face vending machine



Mobile remote control
Remote audit/price change/
lighting/temperature



Intelligent temperature control
Cold and hot dual temperature
intelligent regulation



Instant receipt
Customer funds arrive more assured



Ultra-large capacity
Can carry 300-800 items



Put an end to arbitrary charges
Smart background is free to use



Adjustable cargo channel
Height and width can be adjusted

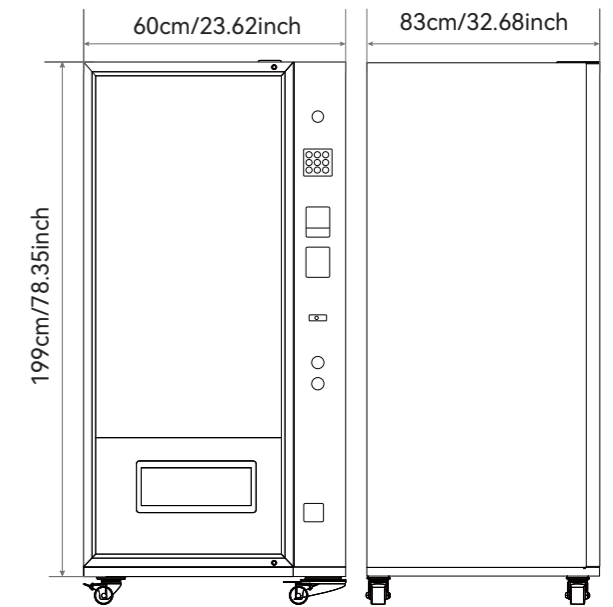

PRODUCT PARAMETERS: 36channels 60 kinds of goods 360capacity

Device model: ZG-ZL-N36-S5

Device size: 600x830x1990mm

Pre-packed size: 650x880x2000mm

Rated voltage: 220V/50HZ

Ambient temperature: cooling temperature

Room temperature power: 35W

Cooling power: 460W

Heating power: 500W (optional)

Defogging power: 40W (optional)

Inventory: 180~360 pieces

Refrigerant number: R290

Weight: 122kg

Pre-packed weight: 124kg

PRODUCT PARAMETER

5 INCH -60 GOODS CHANNEL

GOOD QUALITY INTELLIGENT PURCHASE

AI smart face vending machine



Mobile remote control
Remote audit/price change/
lighting/temperature



Intelligent temperature control
Cold and hot dual temperature
intelligent regulation



Instant receipt
Customer funds arrive more assured



Ultra-large capacity
Can carry 300-800 items



Put an end to arbitrary charges
Smart background is free to use



Adjustable cargo channel
Height and width can be adjusted

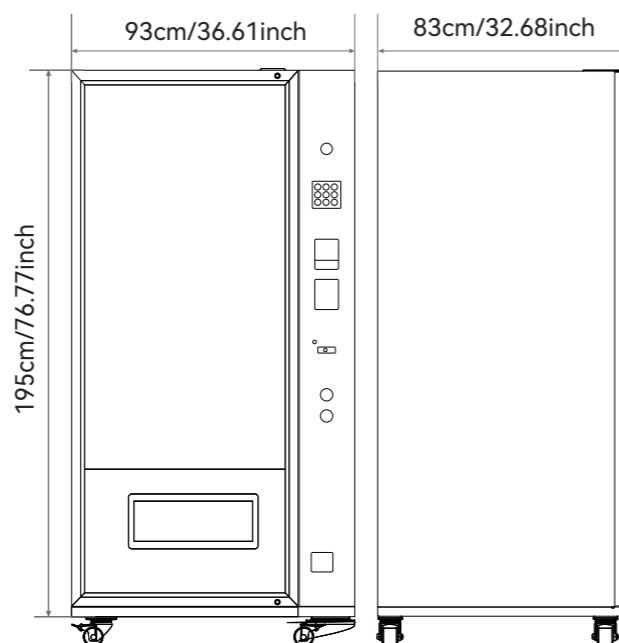

PRODUCT PARAMETERS: 60 channels 60 kinds of goods 600 capacity

Device model: ZG-ZL-N60-S5

Device size: 930x830x1950mm

Pre-packed size: 980x890x1950mm

Rated voltage: 220V/50HZ

Ambient temperature: cooling temperature

Room temperature power: 35W

Cooling power: 460W

Heating power: 500W (optional)

Defogging power: 40W (optional)

Inventory: 300~600 pieces

Refrigerant number: R290

Weight: 168kg

Pre-packed weight: 171kg



Other Products





PRODUCT PARAMETER

15.6 INCH 60 GOODS CHANNEL +18 GRIDS

GOOD QUALITY INTELLIGENT PURCHASE

AI smart face vending machine

- 
Mobile remote control
Remote audit/price change/
lighting/temperature
- 
Instant receipt
Customer funds arrive more assured
- 
Ultra-large capacity
Can carry 300-800 items
- 
Put an end to arbitrary charges
Smart background is free to use
- 
Adjustable cargo channel
Height and width can be adjusted

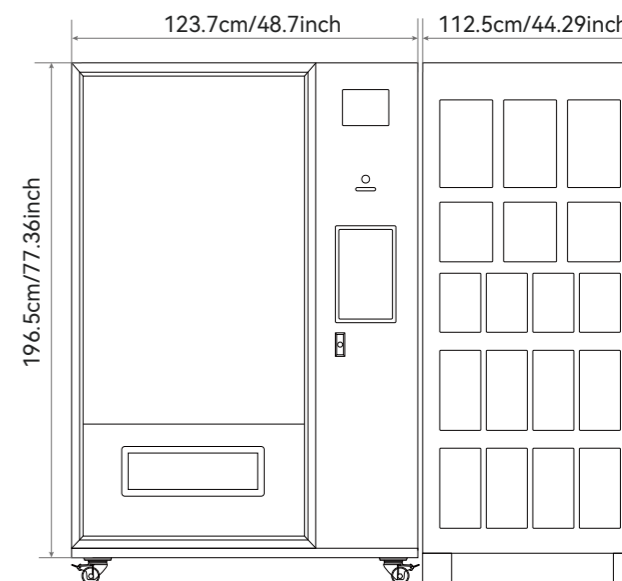

PRODUCT PARAMETERS: 15.6 inch vending machine +18 lattice cabinet

Device model: ZG-ZL-N60-S15.6+ZG-GZ-N18

Equipment size: (main cabinet: 1237x830x1965mm sub-cabinet :1125*330*1955mm)

Pre-packing size: (main cabinet :1280x880x1980mm sub-cabinet :1170*380*1970mm)

Rated voltage: 220V/50HZ Ambient temperature: cooling temperature + room temperature

Room temperature power: 40W+60W Cooling power: 460W

Heating power: 500W (optional) Defogging power: 40W (optional)

Inventory: 618 parts refrigerant No. : R290

Weight: 297kg Pre-packed weight: 304kg

Product parameters: 18 lattice cabinet

Device model: ZG-GZ-N18
 Equipment size: 1125x330x1955mm
 Pre-packed size :1170x380x1970mm
 Rated voltage: 220V/50HZ
 Ambient temperature: normal temperature
 Room temperature power: 60W
 Inventory: 18 grids
 Weight: 89kg
 Pre-packed weight: 92kg



Product parameters: 40 lattice cabinet

Device model: ZG-GZ-N40 (PC door)
 Equipment size: 900x330x1955mm
 Pre-packed size :950x380x1970mm
 Rated voltage: 220V/50HZ
 Ambient temperature: normal temperature
 Room temperature power: 90W Inventory: 40 grids
 Weight: 87kg Pre-packed weight: 90kg

Device model: ZG-GZ-N40 (Metal door)
 Device size: 1125x330x1955mm
 Pre-packed size :1170x380x1970mm
 Rated voltage: 220V/50HZ
 Ambient temperature: normal temperature
 Room temperature power: 90W Inventory: 40 grids
 Weight: 110kg Pre-packed weight: 113kg

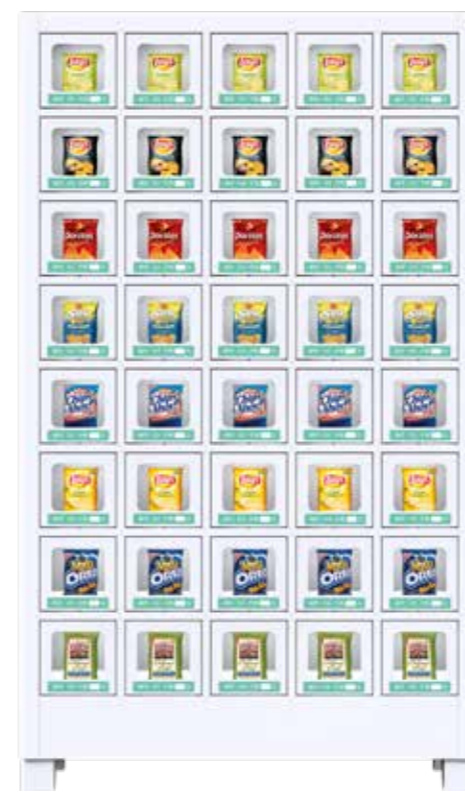

Product parameters: 27 lattice cabinet

Device model: ZG-GZ-N27
 Equipment size: 1125x330x1955mm
 Pre-packed size :1170x380x1970mm
 Rated voltage: 220V/50HZ
 Ambient temperature: normal temperature
 Room temperature power: 80W
 Inventory: 27 grids
 Weight: 99kg
 Pre-packed weight: 102kg



Product parameters: 60 lattice cabinet

Device model: ZG-GZ-N60
 Device size: 900x330x1955mm
 Pre-packed size :950x380x1970mm
 Rated voltage: 220V/50HZ
 Ambient temperature: normal temperature
 Room temperature power: 100W
 Inventory: 60 grids
 Weight: 96kg
 Pre-packed weight: 99kg



A vending machine for adult products
15.6 INCHES 30 CARGO LANES
+14 GRIDS



▶ PRODUCT PARAMETERS:

Product model :ZG-CW-N44-S15.6

Product capacity :44 kinds/capacity of about 300 pieces

Box structure: main cabinet spring machine + auxiliary cabinet lattice machine

Standard cargo channel :30 cargo channel +14 lattice cabinet

Applicable products: adult products/family planning products, etc

A vending machine for adult products
15.6 INCHES 30 CARGO LANES
+14 GRIDS+16 GRIDS



▶ PRODUCT PARAMETERS:

Product model :ZG-CW-N44-S15.6+SM-GZ-N16

Product size: Main cabinet: 1800*875*595mm Secondary cabinet: 1800*875*331mm (14/16 lattice cabinet)

Equipment weight :197kg

Equipment power :120W Product capacity :60 kinds/capacity of about 300 pieces

Box structure: main cabinet spring machine + auxiliary cabinet lattice machine

Standard cargo channel :30 cargo channel +14+16 grids

Applicable products: adult products/family planning products, etc

21.5-INCH TOUCH SCREEN NORMAL TEMPERATURE GRAIN AND OIL CABINET



Hd touch screen

32 "HD touch screen,
Facial payment machines
are more beautiful,
More convenient consumption



Intelligent control

Mobile remote control
Data statistics,
fault diagnosis, etc



Ultra-large capacity

Flexible cargo channel,
space utilization
High capacity,
reduce the number of replenishment



The return cycle is short

High cost performance
High acceptance of the crowd,
strong profitability



Products and application scenarios

Flexible selection of goods,
community,
Factories, hospitals,
streets, etc



4G

4G Internet of Things

4G iot, quick response
Order response, 5 seconds to ship



Product name: Grain and oil tank host + auxiliary machine

Equipment Model: ZG-GZ-N3+ZG-GZ-N12(2 PCS)

Dimensions: Host :460x465x2065mm

Auxiliary cabinet :920x465x2065mm

Pre-packed dimensions: Host :510x510x2080mm

Sub-cabinet :970x510x2080mm

Rated voltage: 220V/50HZ

Ambient temperature: normal temperature

Room temperature power: 40W +60W

Inventory: N3+N12+N12

Weight: 280kg

Pre-packed weight: 286kg

21.5 INCH TOUCH SCREEN LABOR PROTECTION MACHINE



Hd touch screen

32 "HD touch screen,
Facial payment machines
are more beautiful,
More convenient consumption



Intelligent control

Mobile remote control
Data statistics,
fault diagnosis, etc



Ultra-large capacity

Flexible cargo channel,
space utilization
High capacity,
reduce the number of replenishment



The return cycle is short

High cost performance
High acceptance of the crowd,
strong profitability



Products and application scenarios

Flexible selection of goods,
community,
Factories, hospitals,
streets, etc



4G

4G Internet of Things

4G iot, quick response
Order response, 5 seconds to ship



Product name: 21.5-inch touch screen labor protection machine

Device model: ZG-CW-N90-S21.5

Device size: 1320x890x1990mm

Pre-packed size :1370x940x2010mm

Rated voltage: 220V/50HZ

Ambient temperature: normal temperature

Room temperature power: 40W

Inventory: 450~900 pieces

Weight: 280kg

Pre-packed weight: 284kg

COMMEMORATIVE COIN VENDING MACHINE



Small and flexible
Small size, large capacity
Flexible delivery, matching a variety of places



The return cycle is short
High cost performance
High acceptance of the crowd, strong profitability



Ultra-large capacity
Flexible cargo channel, space utilization
High capacity, reduce the number of replenishment



Internet celebrity project
The audience is wide, suitable for all ages
Never go out of date



High playability
Simple operation, strong sense of ritual
Immersive experience



Product name: Commemorative coin self-service vending machine

Device model: ZG-YB-N4

Equipment size: 600x895x1980mm Pre-packed size :650x940x2000mm

Rated voltage: 220V/50HZ Ambient temperature: normal temperature

Room temperature power: 90W Deposit: 65 pieces

Weight: 93kg Pre-packed weight: 96kg

AUTOMATIC SIGNING MACHINE



Small and flexible
Small size, large capacity
Flexible delivery, matching a variety of places



The return cycle is short
High cost performance
High acceptance of the crowd, strong profitability



Ultra-large capacity
Flexible cargo channel, space utilization
High capacity, reduce the number of replenishment



Internet celebrity project
The audience is wide, suitable for all ages
Never go out of date



High playability
Simple operation, strong sense of ritual
Immersive experience



Product name: Scanning code self-service visa machine

Device model: ZG-CQ-N255

Equipment size: 600*895*1980mm Pre-packed size :650*940*2000mm

Rated voltage: 220V/50HZ Ambient temperature: normal temperature

Room temperature power: 90W loading capacity: 800 signatures

Weight: 93kg Pre-packed weight: 96kg

CUSTOMER CASE DISPLAY



CUSTOMER CASE DISPLAY

